



SPECIFICATION

Current Rate:3 AMP
 Insulation Resistance:1000M Ω Min
 Contact Resistance:13m Ω Max
 Dielectric voltage:500V AC for one minute
 Operation Temperature:-55°C to +105°C

MATERIAL

Insulator:PBT+30% Glass Fiber(UL94V-0)
 Contact Pin:F:Phosphor Bronze or Brass
 M:Brass

ORDER INFORMATION

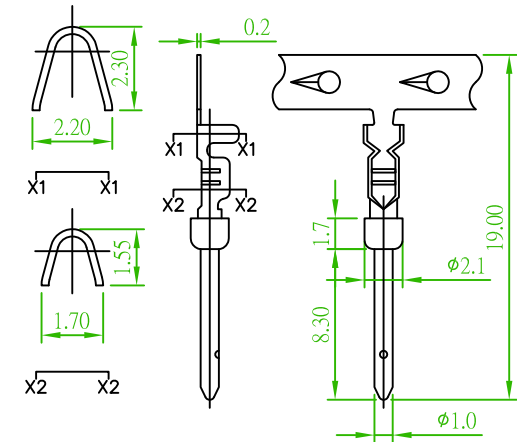
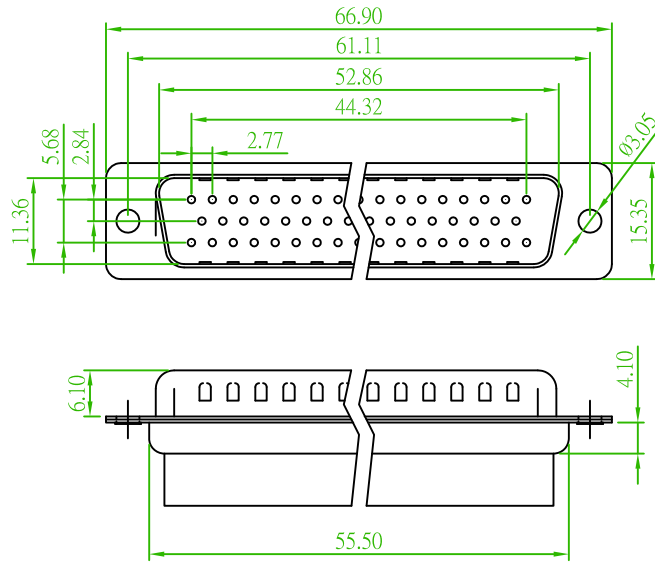
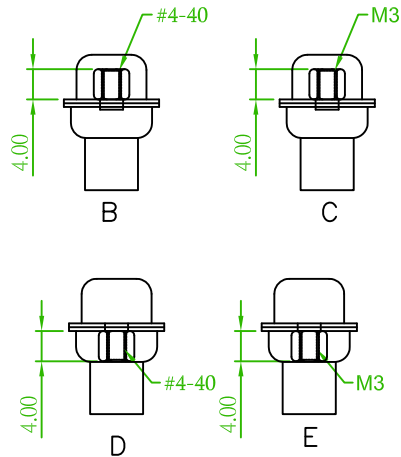
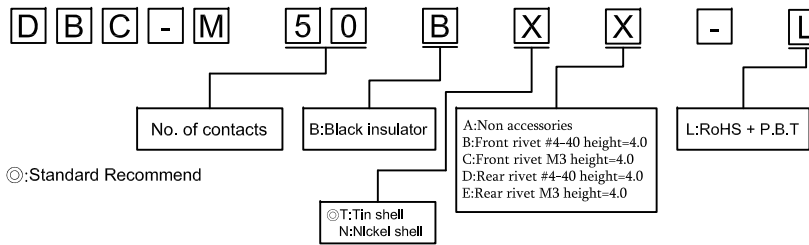

1.0 Crimp Pin Male Terminal
 24~26 AWG Gold
 PART No.:DBC-MT

AREA	REV.	DESCRIPTION	DATE

Amtek Technology Co., Ltd.
 TEL:886-2-2268-8036
 FAX:886-2-2268-8035

品名 TITLE	D-SUB CRIMP TYPE				
品號 PART NO.	DBC-M50-L			日期 DATE	04/02/2007
圖號 DRAWING NO.	DBC-M50-L	版本 REV.	A	繪圖 DRAWN	Kent
客戶品號 CUSTOMER P/N		比例 SCALE	1:1	核對 CHECKED	Paul
公差 TOLERANCE	.X ±0.25 .XX ±0.2	單位 UNIT	mm	核准 APPROVED	James